

AHP2500 型气动液压泵

Air-Driven High Pressure Pump AHP-2500



使用指南

Instructions for use

常州艾乐森动力技术有限公司

PRELIMINARY OPERATING INSTRUCTION FOR PUMP UNIT TYPE AHP-2500

This instruction has been made to facilitate the understanding of the various control instruments and maneuvering handles are fitted with a number. These numbers are mentioned in this instruction and are also referring to the numbers found on the drawings showing the complete pump unit.

Furthermore, these numbers are found on the instrument panel of the pump unit. Please, read this direction of use carefully before using the pump unit and follow the instructions given very carefully of the working principles of the pump unit.

. (Note: Be sure to fill up with oil before using)

BEFORE CONNECTING THE PUMP UNIT:

The tank is filled with oil through the filler cap(6) in the right side of the top panel.

Oil: Any good hydraulic oil may be used.

a) Open oil return valve(1) by turning anti-clockwise.

b) The handle of the regulator valve(3) should be turned 4-5 turns anti-clockwise. This is done to avoid the pump starting at a too high pressure level.

c) Stop valve(2) should be turned clockwise, to close the valve. This is done to ensure that the pump will not work at will when the primary pneumatic system is connected.

CONNECTION OF PUMP:

Compressed air is led through a flexible hose and is connected to the stud marked "air inlet"(7) on the right side of the cabinet. This stud has an 1/2 B.S.P. female thread. The hydraulic system is connected to the stud marked "high pressure outlet"(8) found on the left side of the cabinet. This stud has a 1/4 B.S.P. female thread. The pump is now ready for use.

The pump may also be operated by hand if compressed air is not available. A handle(9) is placed in a retainer on the top panel. It may easily be fitted to the pump through the slot in the slot in the left side plate by pressing it into the bushing found inside the slot.

START OF PUMP:

a) Stop valve(2) is turned slowly anti-clockwise, where by compressed air enters into the pump unit, which commences to work. The stop valve(2) is also acting as a regulator valve for the pumping speed.

b) The regulator valve(3), which is used for adjusting the pressure is now turned clockwise and the hydraulic pressure may now be read on the manometer for pressure control(4). This manometer

shows the hydraulic high pressure in bar.

c) The oil return valve(1) is closed by turning the knob clockwise and the oil will then run from the oil tank into the hydraulic system. When the hydraulic system has been filled, and the pump has stopped operating, the high pressure reached can be read at the manometer for working pressure(5) found on the left side of the instrument panel. The pump stops automatically, when the required high pressure has been established and holds it infinitely. The Pump starts automatically again if a pressure drop occurs in the hydraulic system.

d) High pressure may be removed from the system by the opening the oil return valve(1) (to be turned anti-clockwise). The excessive oil in the secondary high pressure system will thereby return to the oil tank in the pump unit.

ENDING OF JOB:

To avoid oil spillage, precautions should be taken to see that the Oil is taken back into the oil tank before the connections on the high pressure side are disconnected. This is done by turning the oil return valve(1) anti-clockwise. Simultaneously the pump should be stopped by turning the stop valve(2) clockwise, and when this valve has been closed, the air hose may be removed and the pump transferred to another job.

DATA FOR HIGH PRESSURE:

The pump unit can deliver a maximum pressure of 2500 bar. At a working pressure of 5.5 bar the pump is adjusted to release at a maximum pressure of 1055 bar. The maximum pressure of 1055 bar (which is pre-set by the factory) secures the rest of the system from overload or faulty operation. The maximum pressure may be pre-set up to 2500 bar, and when the pump unit is being used for other pressures than 7 bar, the release valve is set at max. 20% above the desired working pressure, but never above 2250 bar.

The release valve, on skeleton drawing, is adjusted by loosening the set screw pos. 43, and adjusting the screw pos. 35 with a screw driver.

Clockwise = higher pressure

Anti-clockwise = lower pressure

Remember to tighten the set screw pos. 43.

CLEANING OF OIL FILTER:

The filter in the filler cap (6) is removed and cleaned when by re-filling the oil starts running through slowly.

SPARE PARTS:

Even though the pump unit is a robust and reliable piece of equipment, there may be a need after a long time of operation for changing various wearing parts like o-rings, seals, and springs—specially in the pressure transformer. In order to facilitate

the ordering of spares,these are listed.

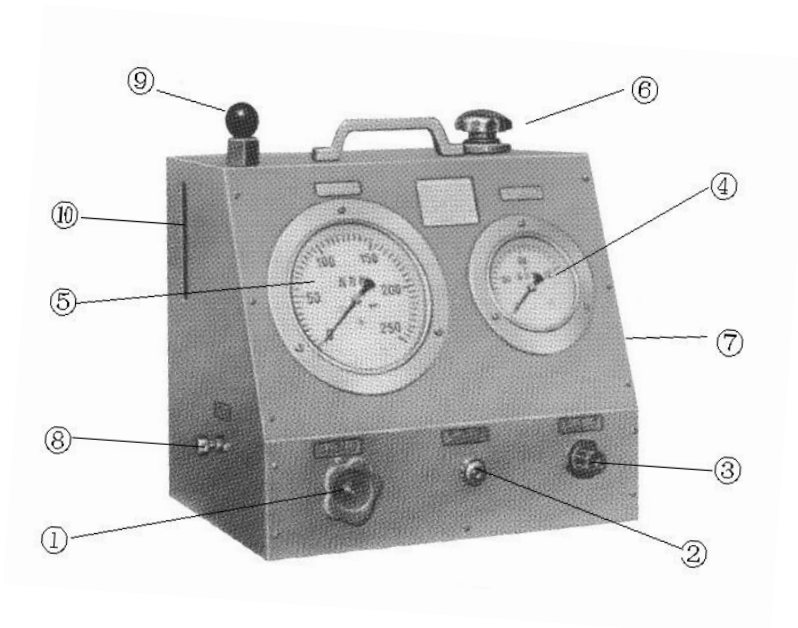
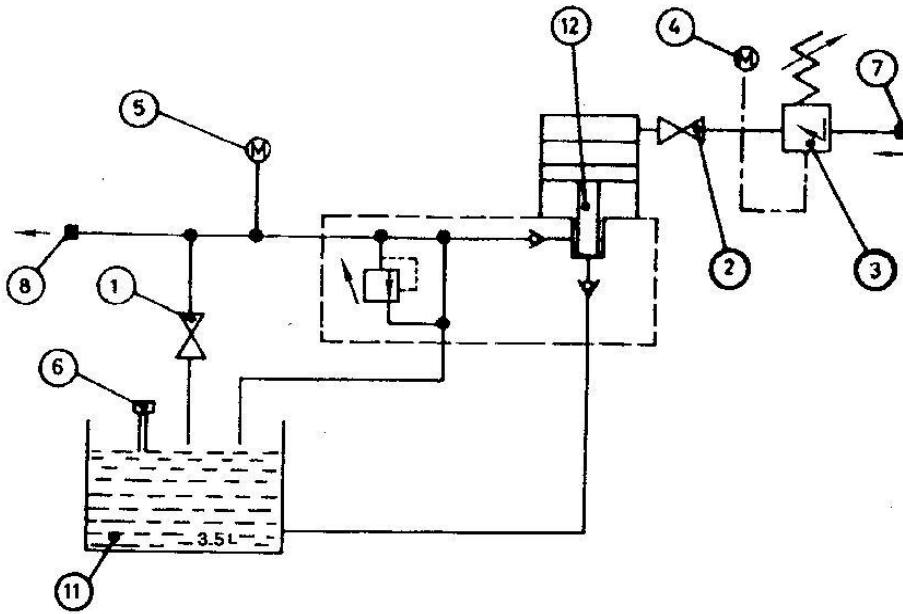

- | | |
|-----------------------------------|---------------------------------------|
| 1、 OIL RETURN VALVE | 2、 STOP VALVE(CYCLING VALVE) |
| 3、 PRESSURE CONTROL VALVE | 4、 MANOMETER PRESSURE CONTROL |
| 5、 MANOMETER FOR WORKING PRESSURE | 6、 FILLER CAP |
| 7、 STUD MARKED" AIR INLET" | 8、 STUD MARKED" HIGH PRESSURE OUTLET" |
| 9、 LEVER FOR HAND PUMPING | 10、 SLOT WITH BUSHING FOR |

LEVER

OUTPUT PRESSURE(Bar):	MAX.2500 BAR AT8.0 BAR AIR INPUT.
TANK CAPACITY (L) :	APPROX.6 LITRES.
PUMPING SPEED:	APPROX.450 CYCLES/MIN.AT8.0 BAR AIR INPUT.
AIR CONSUMPTION:	300 LITRED/MIN.AT 8.0 BAR AIR INPUT.
MAX.FLOW AT NO PRESSURE:	APPROX. 0.45 LITRES/MIN.AT 8.0 BAR AIR INPUT..
WEIGHT (Kg)	24 KILOS EMPTY
DIMENSIOND (mm)	380*360*380MM
AIR ACCESS PORT	1/2BSP.STANDARD INTERNAL THREAD
HIGH-VOLTAGE OUTPUT	G1/4.STANDARD INTERNAL THREAD

TECHNICAL PARAMETERS:

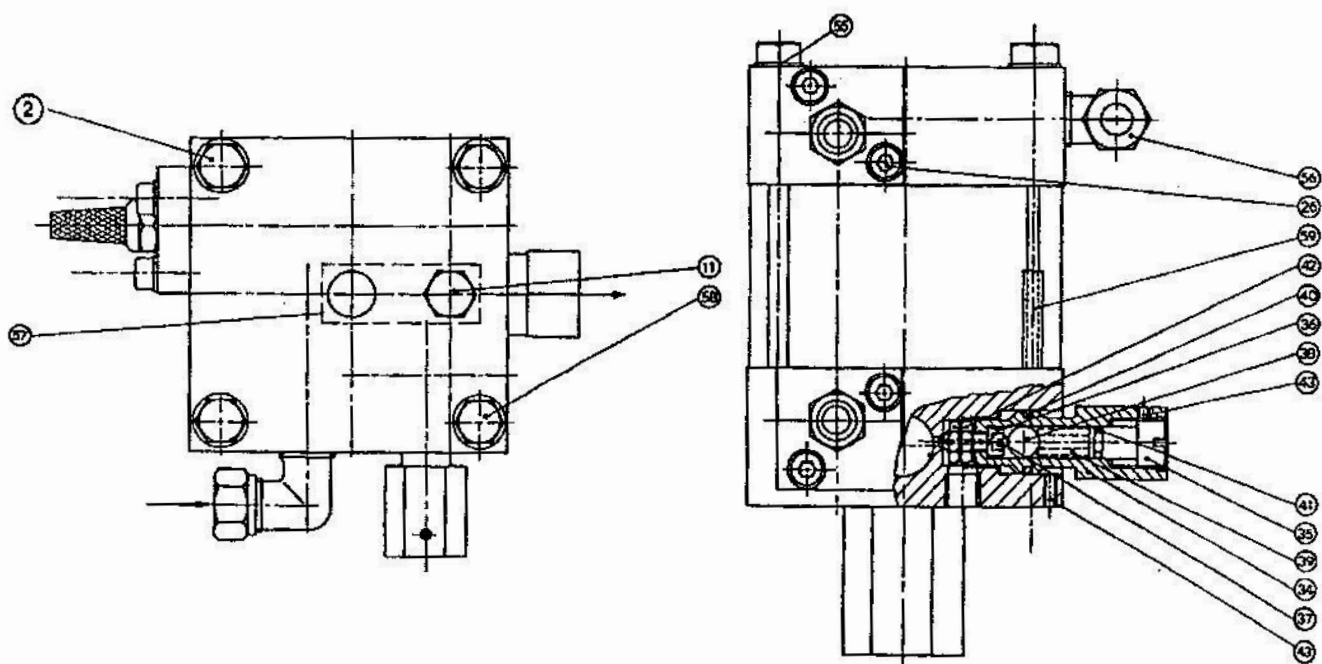
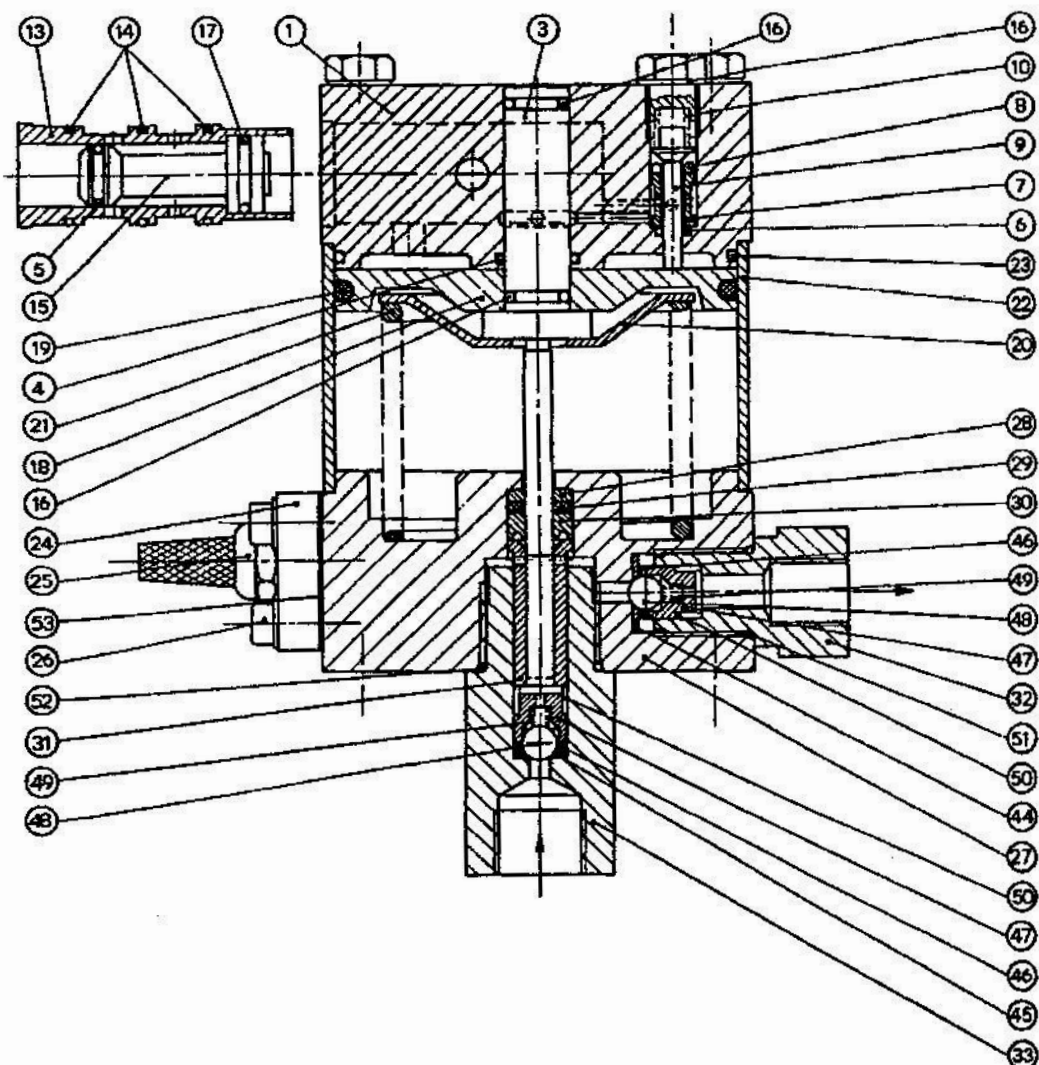

INVENTORY LIST:

S N	NAME	QUANTITY	S N	NAME	QUANTITY
1	Top cap	1	31	Spacer	1
2	Cylinder head screw	4	32	Fitting oil out	1
3	O-ring	1	33	Fitting oil out	1
4	O-ring	1	34	Valve body	1
5	O-ring	1	35	Adjusting screw	1
6	O-ring	1	36	Poppet	1
7	Tube	1	37	Ball	1
8	O-ring	1	38	Ball	1
9	Pilot valve	1	39	Spring	1
10	Spring	1	40	O-ring	1
11	Plug	1	41	O-ring	1
12	O-ring	1	42	Nut	1
13	Sleeve	1	43	Locking screw	1
14	O-ring	3	44	Seat	3
15	Spool	1	45	Seat	1
16	O-ring	1	46	Ring	3
17	O-ring	1	47	Cage	1
18	Air piston	1	48	Ball	1
19	O-ring	1	49	Spring	1
20	Spring support	1	50	Spring	1
21	Spring	1	51	O-ring	1
22	Cylinder tube	1	52	O-ring	1
23	O-ring	1	53	Diaphragm	1
24	Exhaust cap	2	54	Bolt	2
25	Silencer	2	55	Washer	2
26	Screw	4	56	Stud air in	4
27	Bottom cap	1	57	Cover	1
28	Support ring	1	58	Bolt	1
29	Support ring	1	59	Spacer	1
30	Seal	1			